

# snorkel

## MHP1335 MHP1544

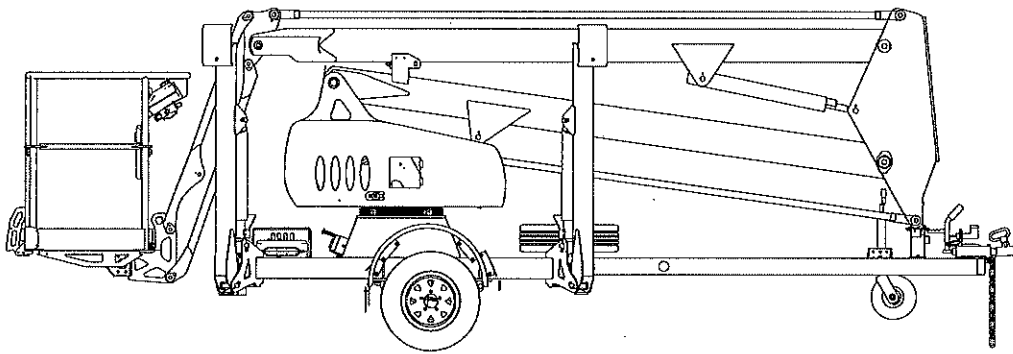

Diesel  
Gasoline  
Battery Electric  
Bi-Energy Options

## OPERATION MANUAL

Part Number 13619-1

November 2012 (Rev C)

Version 3

Serial Number MHP1335-07-000003 and after

## ■ Safe Operation

Knowledge of the information in this manual, and proper training, provide a basis for safely operating the MHP13/35 / MHP15/44 V3. Know the location of all the controls and how they operate to act quickly and responsibly in an emergency.

Safety devices reduce the likelihood of an accident. Never disable, modify, or ignore any safety device. Safety alerts in this manual indicate situations where accidents may occur.

If any malfunction, hazard or potentially unsafe condition relating to capacity, intended use, or safe operation is suspected, stop the operation of the MHP and seek assistance.

The operator bears ultimate responsibility for following all manufacturers instructions and warnings, regulations and safety rules of their employer and/or any country or regional law.

## ■ Electrocuting Hazards

The MHP is an all metal boom aerial work platform and is not electrically insulated. Do not operate it near electrical conductors. Regard all conductors as being energised. Do not operate outside during a thunderstorm.

## ■ Pre-start Inspection

At the start of each work shift, the MHP13/35 / MHP15/44 V3 shall be given a visual inspection and function test. See the "Daily Inspection and Maintenance" chapter 7, in this manual for a list of items to inspect and test.

## ▲ WARNING

**DO NOT operate the MHP13/35 / MHP15/44 V3 unless you are trained and authorised, understand the operation characteristics of the MHP13/35 / MHP15/44 V3, and have inspected and tested all functions to be sure they are in proper working order.**

## ■ Work Place Inspection and Practices

Do not use the MHP13/35 / MHP15/44 V3 as a ground for welding. Ground to the work piece.

Before the MHP13/35 / MHP15/44 V3 is used, and during use, check the area in which the MHP13/35 / MHP15/44 V3 is to be used for possible hazards such as, but not limited to:

- Drop-offs or holes.
- Side slopes.
- Bumps and floor obstructions.

- Debris.
- Overhead obstructions and electrical conductors.
- Hazardous locations.
- Inadequate surface and support to withstand all load forces imposed by the aerial platform in all operating configurations.
- Wind and weather conditions.
- Presence of unauthorised persons.
- Other possible unsafe conditions.

Before the MHP13/35 / MHP15/44 V3 is used, determine the hazard classification of any particular atmosphere or location according to ANSI/NFPA 505-1987.

Any MHP13/35 / MHP15/44 V3 operated in a hazardous location must be approved and of the type required by ANSI/NFPA 505-1987.

While operating the MHP a recommended safety practice is to have trained and qualified personnel in the immediate work area of the MHP13/35 / MHP15/44 V3 to:

- Help in case of an emergency.
- Operate emergency controls as required.
- Watch for loss of control by platform operator.
- Warn the operator of any obstructions or hazards that may not be obvious to them.
- Watch for soft terrain, sloping surfaces, drop-offs, etc., where stability could be jeopardized.
- Watch for bystanders and never allow anyone to be under, or to reach through the booms while operating the aerial platform.

## ▲ DANGER

**Pinch points may exist between moving components. Death or serious injury can result from becoming trapped between components, buildings, structures, or other obstacles. Make sure there is sufficient clearance around the machine before moving the chassis, booms, or platform. Allow sufficient room and time to stop movement to avoid contact with structures or other hazards.**

Keep ground personnel from under the platform when the platform is raised.

Secure all accessories, containers, tools, and other materials in the platform to prevent them from accidentally falling or being kicked off the platform.

# 1. Safety

---

Always look in the direction of travel. Drive with care and at speeds compatible with the work-place conditions. Use caution when driving over rough ground, on slopes, and when turning.

Do not engage in any form of "horseplay" or "stunt driving" while operating the MHP13/35 / MHP15/44 V3.

Do not permit riders on the machine anyplace other than on the platform.

Remove all loose objects stored in or on the machine, particularly in the platform. Remove all objects which do not belong in or on the machine.

Never steady the platform by positioning it against another platform.

Do not operate an MHP13/35 / MHP15/44 V3 that is damaged or not functioning properly. Do not use the MHP until the machine has been repaired by a qualified maintenance person.

Do not operate a MHP13/35 / MHP15/44 V3 that does not have all its decals and placards attached and legible.

Watch for bystanders and never allow anyone to be under, or to reach through, the machine and its equipment while operating.

Use the recommended transport device when loading the machine.

## ■ Operation

If you encounter any suspected malfunction of the aerial platform, or any hazard or potentially unsafe condition relating to capacity, intended use, or safe operation, cease operation immediately and seek assistance from management.

Use three (3) points of support when getting on or off the platform (two (2) hands and one (1) foot or a similar set of points). Keep the platform clean.

Maintain a firm footing on the platform floor. Operate the controls slowly and deliberately to avoid jerky and erratic operation. Always stop the controls in neutral before going in the opposite direction.

Do not dismount while the platform is in motion or jump off the machine.

Do not start until all personnel are clearly away from the machine.

Never cover the floor grating or otherwise obstruct your view below. Make sure the area below the platform is free of personnel before lowering.

## ■ Tipover and Falling Hazards

Operate the MHP only on a firm, flat, level surface capable of withstanding all load forces imposed by the MHP13/35 / MHP15/44 V3 in all operating conditions.

### ▲ DANGER

**The MHP can tip over if it becomes unstable. Death or serious injury can result from a tip-over accident. Do not drive or position the MHP platform for elevated use near any drop-off, hole, slope, soft or uneven ground, or other tip-over hazard.**

Do not operate the MHP13/35 / MHP15/44 V3 from a position on trucks, trailers, railway cars, floating vessels, scaffolds, or similar equipment unless the application is approved in writing by Snorkel.

Care shall be taken to prevent rope, electric cords, and hoses, etc., from becoming entangled in the aerial platform. If the platform or elevating assembly becomes caught, snagged, or otherwise prevented from normal motion by an adjacent structure or other obstacle such that control reversal does not free the platform, remove all personnel from the platform before attempts are made to free the platform using ground controls.

No person shall access or egress from the platform in the elevated position (except in an emergency) unless the requirements of AS2550.10 have been met.

For full requirements refer directly to AS2550.10.

All platform occupants **MUST** wear and use safety harness. Attach safety harness to the platform lanyard anchor points.

Do not exceed the unrestricted platform capacity as indicated on the capacity placard at the entrance to the platform. Do not carry loads from any point outside of the platform.

Make sure that all protective guards, cowlings, and doors are in place and secure. Be sure the guard-rail system, including the gate, is in place and secure.

Do not climb on the guardrails or use ladders, planks, or other devices to extend or increase your work position from the platform.

Do not use the MHP as a crane, hoist, or jack, or for any other purpose other than to position personnel, their tools, and materials.

Do not operate the MHP13/35 / MHP15/44 V3 in winds, or wind gusts, of 28 mph, 45kph 12.5 m/s) or more.

**▲ DANGER**

Do not add banners, flags, screens or shelters etc., to areas of the MHP that are exposed to wind forces as this will increase the wind loading and effect stability.

**■ General Safety Precautions**

Do not modify the MHP13/35 / MHP15/44 V3 in any way.

When parts or components are replaced, they shall be identical or equivalent to original Snorkel parts or components.

Do not override any of the safety features of the MHP13/35 / MHP15/44 V3.

**■ Hydraulic System Precautions**

The hydraulic system contains hoses with hydraulic fluid under pressure.

**▲ DANGER**

Hydraulic fluid escaping under pressure can have enough force to inject fluid into the flesh. Serious infection or reaction can result if medical treatment is not given immediately. In case of injury by escaping hydraulic fluid, seek medical attention at once.

DO NOT place your hand or any part of your body in front of escaping hydraulic fluid. Use a piece of cardboard or wood to search for hydraulic leaks.

Do not attempt repairs to hydraulic systems unless you are trained. Refer to experienced repair personnel for help.

**■ Fire Prevention**

Never operate your MHP near a flame or spark. Hydraulic oil and gasoline are flammable and can explode.

**NOTE:**

*This machine is equipped with an internal combustion engine (in it's standard configuration) and should not be used on or near any unimproved forest-covered, brush-covered or grass covered land unless the engine's exhaust system is equipped with a spark arrester meeting applicable laws. If a spark arrester is used, it should be maintained in effective working order by the operator.*

**■ Engine and Fuel Handling Precautions****▲ DANGER**

Engine exhaust contains carbon monoxide, a poisonous gas that is invisible and odorless. Breathing engine exhaust fumes can cause death or serious illness. Do not run the engine in an enclosed area or indoors without adequate ventilation.

Only refuel your MHP outdoors in a clear area void of gas fumes or spilled gas.

Never remove the fuel cap or refuel a gasoline engine while the engine is running or hot. ALWAYS allow the engine to cool before refueling. Never allow fuel to spill on hot machine components.

**▲ DANGER**

**DO NOT smoke or permit open flames while fueling or near fueling operations.**

Maintain control of the fuel filler nozzle when filling the tank.

**▲ CAUTION**

**ENSURE** you use an approved fuel container with appropriate fuel filler nozzle (see picture below)

**Correct Method to Fill MHP13/35 / MHP15/44 V3 Fuel Tank**

Do not fill the fuel tank to capacity. Allow room for expansion.

If gasoline is spilled, clean up spilled fuel immediately, push/tow the MHP away from the area of the spill and avoid creating any source of ignition until the spilled fuel has evaporated.

# 1. Safety

---

Tighten the fuel tank cap securely. If the fuel cap is lost, replace it with an approved cap from Snorkel. Use of a non-approved cap without proper venting may result in pressurization of the tank.

Never use fuel for cleaning purposes.

For diesel engines, use the correct fuel grade for the operating season.

## ■ Batteries

Charge batteries in a well ventilated area free of flame, sparks, or other hazards that might cause fire or explosion.

### ▲ WARNING

**Batteries give off hydrogen and oxygen that can combine explosively. Death or serious injury can result from a chemical explosion. Do not smoke or permit open flames or sparks when checking batteries.**

**Battery acid can damage the skin and eyes. Serious infection or reaction can result if medical treatment is not given immediately. Wear face and eye protection when working near batteries.**

Batteries contain sulfuric acid that can damage your eyes or skin on contact. Wear a face shield, rubber gloves, and protective clothing when working around batteries.

### ▲ CAUTION

**If acid contacts your eyes, flush immediately with clear water and get medical attention. If acid contacts your skin, wash off immediately with clear water.**

## ■ 10.9 Metre Restriction Kit

MHP15/44 Mark II machines that are built for the Australian market may be fitted with a 10.9m restriction kit.

This kit is fitted to restrict the maximum height to the platform floor at 10.9 meters from the ground. This is to allow the unit to be operated by unlicensed operators in accordance with Australian legislation.

### ▲ WARNING

**The operator MUST hold a WP Certificate of Competency in order to operate the machine at heights in excess of 11m.**

### Note:

*See the Options chapter for details concerning this kit.*

## ■ Safety Decals and Placards

There are various safety decals and placards on the MHP13/35 / MHP15/44 V3. Their locations and descriptions are shown in this section. Take time to study them.

### ▲ CAUTION

**Be sure that all the safety decals and placards on the MHP13/35 / MHP15/44 V3 are legible. Clean or replace them if you cannot read the words or see the pictures. Clean with soap & water and a soft cloth. Do not use solvents.**

### Note:

*From time-to-time certain Snorkel decals may be deleted, altered or replaced, or new decals may be added in line with new safety regulations or machine specification changes.*

*If you are unsure or want to check a particular decal or its placement on the machine contact your nearest Snorkel dealer or the snorkel website.*

### ▲ CAUTION

You **MUST** replace a decal or placard if it is damaged, missing, or cannot be read. If it is on a part that is replaced, make sure a new decal or placard is installed on the replaced part. See your Snorkel dealer for new decals and placards.

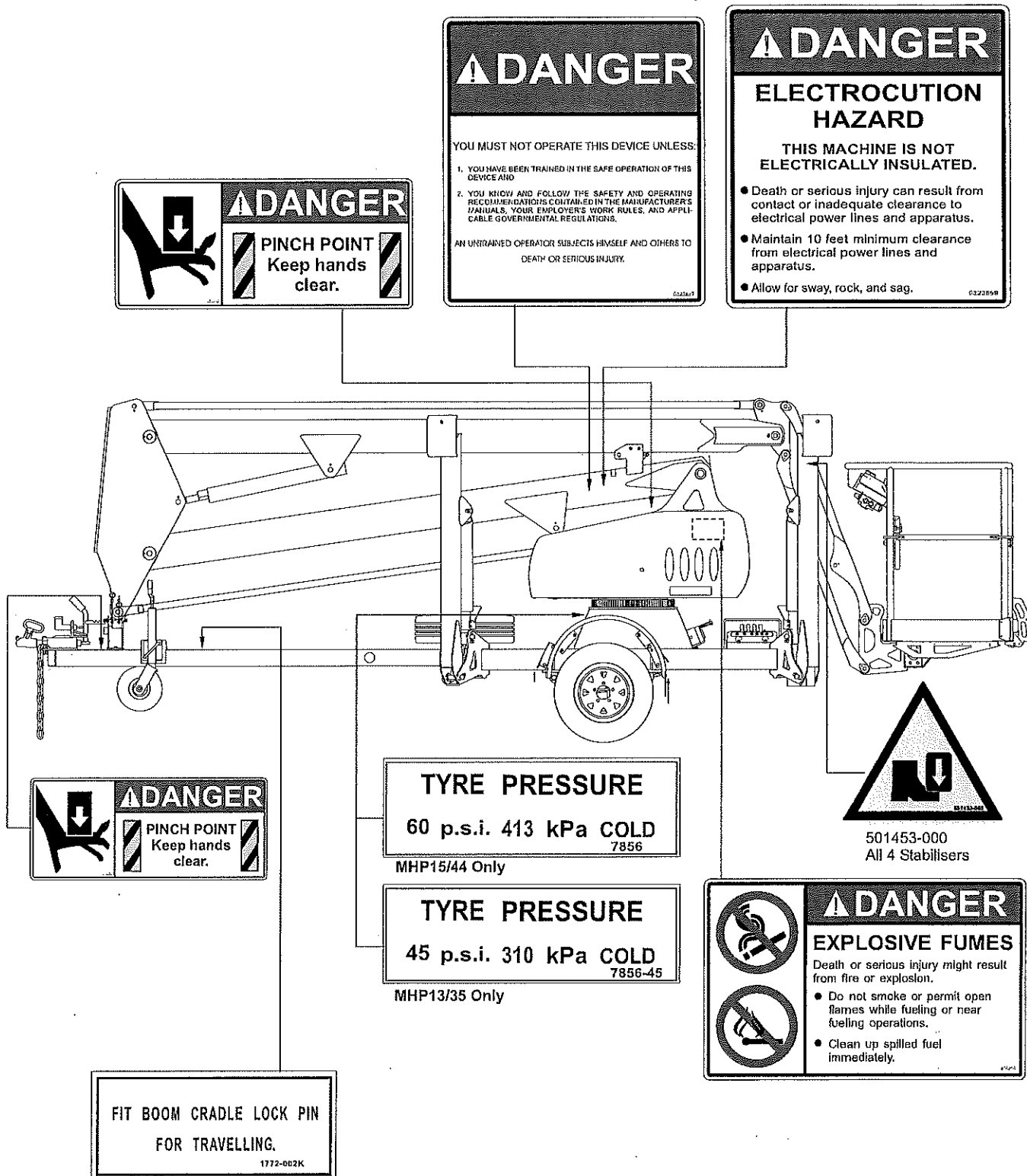

# 1. Safety

**APPROVED OVERHEAD LIFT METHOD FOR MHP TRAILERS**

1. CHAIN SLING, 4 LEGS AT 2.5M LEG (Minimum 2mm gap to 40 LBSing rule)
2. ENSURE STABILISERS ARE FULLY RAISED
3. FIT A SHACKLE TO EACH FOOT PLATE (From 10m-Load (green pin) New 8m-Load)
4. CONNECT SLING LEGS WITH CLOSED HOOKS
5. ENSURE THE JOCKEY WHEEL IS STOWED
6. ENSURE THAT THE BOOM SECURING PINS ARE FITTED

12312

**FIT BOOM CRADLE LOCK PIN FOR TRAVELLING.**  
1772-002K

**⚠ DANGER**  
KEEP CLEAR OF DESCENDING BOOM  
DEATH OR SERIOUS INJURY CAN OCCUR FROM DESCENDING BOOM  
012621

**OPERATORS CHECKLIST**  
INSPECT AND/OR TEST THE FOLLOWING DAILY OR AT THE BEGINNING OF EACH SHIFT

1. OPERATING AND EMERGENCY CONTROLS.
2. SAFETY DEVICES.
3. PERSONAL PROTECTIVE DEVICES.
4. HOSES, FITTINGS AND VALVES FOR LEAKS.
5. CABLES AND WIRING HARNESS.
6. LOOSE OR MISSING PARTS.
7. TYRES AND WHEELS.
8. PLACARDS, WARNINGS, CONTROL MARKINGS AND OPERATING MANUAL(S).
9. GUARDRAIL SYSTEM.
10. OIL LEVELS.
11. BATTERY FLUID LEVEL.

300699

**WARNING**  
THIS MACHINE IS FITTED WITH A 10.9 METRE RESTRICTION KIT  
SELECTION / OPERATION OF A BOOM LENGTH IN EXCESS OF 11M REQUIRES THE OPERATOR TO HOLD A WP CERTIFICATE OF COMPETENCY  
MHP15/44 Australia Only 13205

**⚠ DANGER**  
DO NOT ALTER OR DISABLE LIMIT SWITCHES, SAFETY SWITCHES, OR INTERLOCKS.  
ALL FOUR STABILISERS  
451926

**WARNING**  
MACHINE MUST BE REMOVED FROM TOWING VEHICLE BEFORE OPERATING

X4 One per each stabiliser leg  
0080650

**TYRE PRESSURE**  
60 p.s.i. 413 kPa COLD  
7856  
MHP15/44 Only

**TYRE PRESSURE**  
45 p.s.i. 310 kPa COLD  
7856-45  
MHP13/35 Only

**EMERGENCY DESCENT**

Turn knob clockwise to operate  
13208-01 A

**MAXIMUM TOWING SPEED**  
80 KPH / 50 MPH

**DANGER**

**BEWARE OF ELECTRICAL HAZARDS**

REGULATION 133A OF THE  
CONSTRUCTION SAFETY ACT 1912 REQUIRES

(a) Minimum approach of an appliance to live electrical apparatus. — 3m, for voltages up to 132,000  
6m, for voltages above 132,000  
and up to 230,000  
8m, for voltages above 330,000

(b) Inspection of the work site for electrical hazards before commencing to use the appliance.

(c) Constant vigilance and an observer required whilst working or traveling the appliance in the vicinity of live electrical apparatus.

9428

(Australia Only) 9428

**WARNING**

**KEEP CLEAR OF POWER LINES**

Unless the Electrical Supply Authority has advised in writing otherwise;  
the clearance between any live overhead power line and any part of this machine or load carried is required by law to be

**AT LEAST 4 METRES**

This is a requirement of regulation 93 of the Electrical Supply Regulations 1984. In the interests of safe working.

1843

(New Zealand Only) 1843

AFTER SERIAL NUMBER NZ070801

**DANGER**

**ELECTROCUTION HAZARD**

THIS MACHINE IS NOT  
ELECTRICALLY INSULATED

13030

BEFORE SERIAL NUMBER NZ070801

**DANGER**

**ELECTROCUTION HAZARD**

This machine is not electrically insulated.

0072531

**DANGER**

MAXIMUM ALLOWABLE  
WIND SPEED 12.5m/sec

0072531

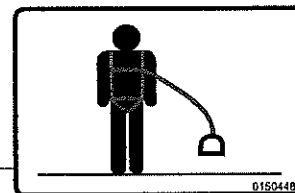
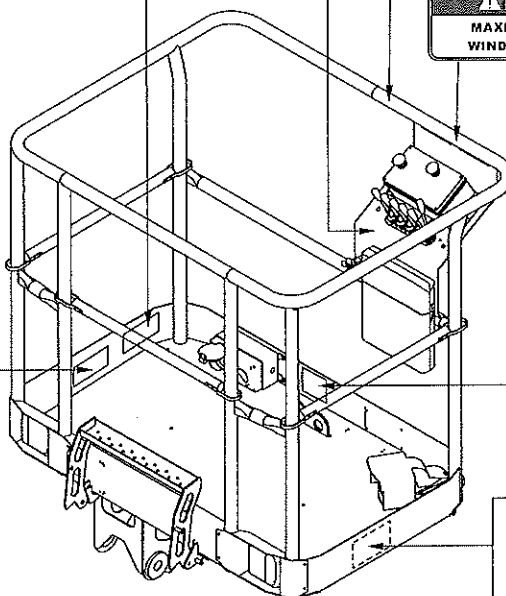

**RATED LOAD**

**440<sup>LB</sup> / 200<sup>KG</sup>**

12423-200

**RATED LOAD**

**500<sup>LB</sup> / 227<sup>KG</sup>**

12423-227

**CAUTION**

EACH PERSON ON THE PLATFORM  
MUST WEAR A FULL SAFETY HARNESS  
WITH LEG STRAPS  
AND ENERGY ABSORBING LANYARD  
ATTACHED TO AN APPROVED ANCHOR  
POINT IN THE PLATFORM

89228-1  
99228-1

Note: Rated capacity depends on the configuration of the machine see Chapter 3 - Specifications

**NOTE:**

Refer to Placards and Decals Inspection Chart and Drawing in the "Daily Inspection and Maintenance" chapter 7, for part numbers, location, and required quantities of all placards and decals.

### ■ Safety Device Information

For emergency operation controls and procedures, see the "Emergency Operation" chapter 9, in this manual.

The devices listed in this chapter are safety devices.

They are on the MHP13/35 / MHP15/44 V3 to increase safety in the work place for both the operator and other people near the MHP13/35 / MHP15/44 V3.

### ▲ WARNING

**DO NOT** by pass, disable, modify, or ignore any of these devices. Check them carefully at the start of each work shift to see that they are in working order (see "Daily Inspection and Maintenance" chapter 7). If any is found to be defective, remove the MHP13/35 / MHP15/44 V3 from service immediately until a qualified service technician can make repairs.

### ■ Emergency Stop Switches

#### □ At ground control box

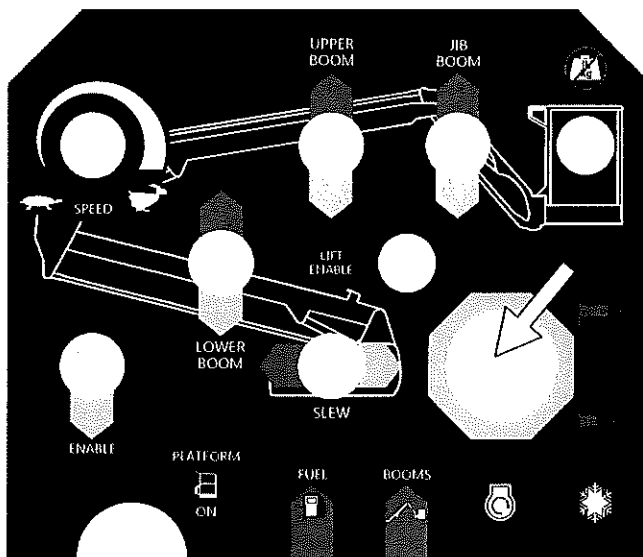

**Figure 2.1 - Emergency Stop Switch at Ground Control Box**

Press the large red **EMERGENCY STOP** switch in, at any time, under any conditions and the entire machine stops, and nothing moves. This emergency stop switch must be out (on) for anything on the MHP13/35 / MHP15/44 V3 to work. Pull the switch and it will pop out.

#### □ At platform control box

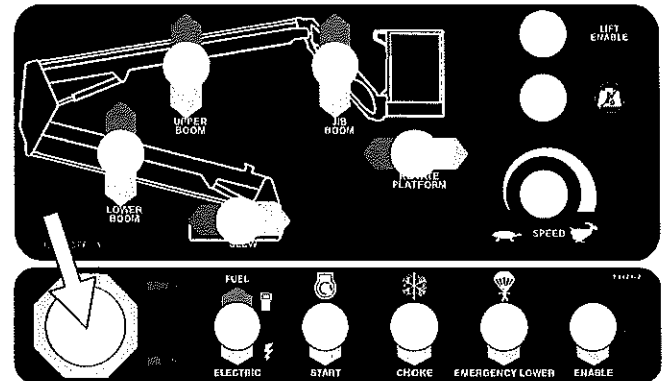

**Figure 2.2 - Emergency Stop Switch at Platform Control Box**

Press the large red **EMERGENCY STOP** switch in, at any time, under any conditions and the entire machine stops, and nothing moves. This emergency stop switch must be out (on) to control the MHP13/35 / MHP15/44 V3 from the platform (pull the switch and it will pop out).

#### NOTE:

*The ground control box is designed to override the platform control box. If the platform control box **EMERGENCY STOP** switch is in (off) the ground control box can still be used to start and operate the MHP13/35 / MHP15/44 V3.*

### ■ Other Safety Devices

#### □ Lanyard anchor points

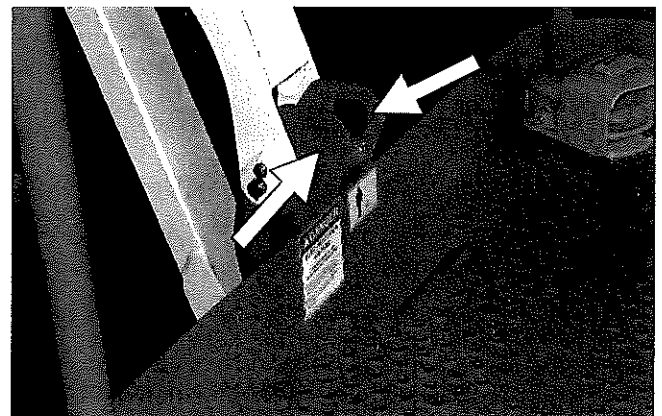

**Figure 2.3 - Lanyard Anchor Points**

All personnel on the platform should attach their safety harness lanyards to one (1) of the lanyard anchor points.

## 2. Safety Devices

### Gravity gate

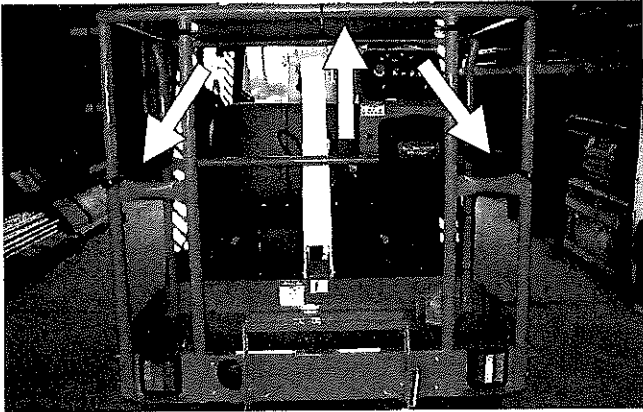

Figure 2.4 - Gravity Gates

The gravity gates are the places in the platform guardrail system where you should enter and leave the platform. Raise the gate where you wish to enter and step under it onto the platform. Once you have entered the platform and attached your safety harness lanyard to an anchor point, check to see that the gravity gate has fallen back into place.

### Guardrails

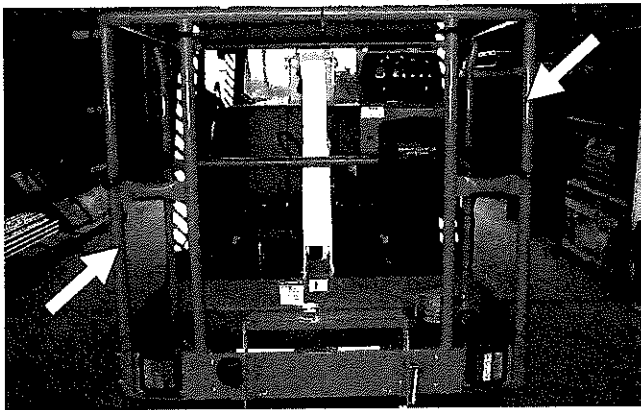

Figure 2.5 - Guardrails

The guardrails help protect you from falling off the platform. Be sure the guardrails are properly installed and that the gravity gate or swinging gate is in place.

### Enable switch

The enable switch must be operated in conjunction with the boom/platform moving function you select. The purpose of this switch is to prevent the platform from moving if something or someone accidentally pushes one of the boom/platform moving controls.

There are enable switches fitted to both the Upper and Lower Control Boxes.

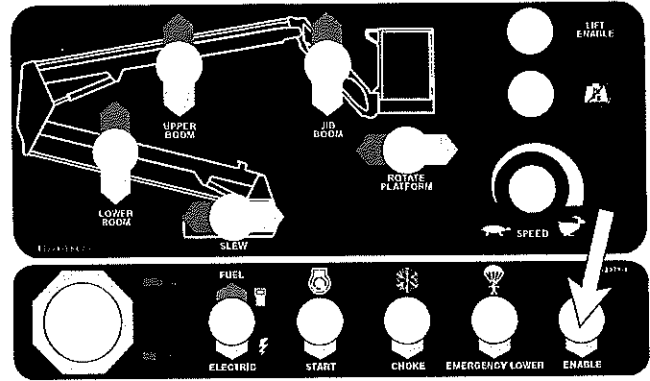

Figure 2.6 - Enable Switch, Platform Control Box

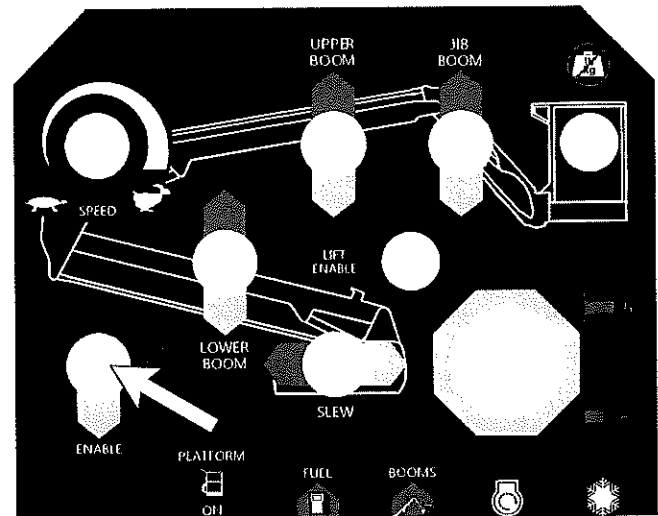

Figure 2.7 - Enable Switch, Ground Control Box

### Enable switch (foot) - Option

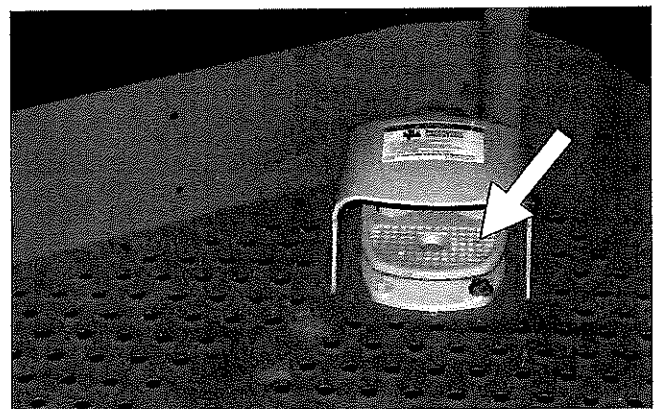

Figure 2.8 - Enable Switch, Foot

The foot switch performs the same function as the standard enable switch described above. Stepping on the foot switch is an action that must be performed, at the same time as another action, to make the platform move.

**Note:**

If you have the optional 'foot switch' fitted the Enable switches on the Upper Control Box and the Ground Control Box will still function.

**Platform overload protection**

As soon as either boom is raised out of the travel cradle (a boom stowed switch changes state) the overload protection system becomes active.

- If **90%** of rated capacity is reached in the platform the overload light will illuminate.

This is a **warning** to the operator that the platform is reaching rated capacity.

Normal function will remain and the machine can continue to be used

- If **100%** of rated capacity is reached in the platform the overload light will continue to be illuminated and an alarm will sound.

This is a **warning** to the operator that rated capacity has been reached and the platform load must be reduced.

Normal function will remain to allow the platform to be positioned to remove some load from the platform.

**Note:**

The machine should not be operated continuously with the overload alarm sounding.

- If **110%** of rated capacity is reached in the platform the overload light will continue to be illuminated and an alarm will continue to sound and all functions will be disabled.

The operator **must remove load** from the platform.

Normal function will resume once the platform load has been reduced below 110% continuously for at least two (2) seconds.

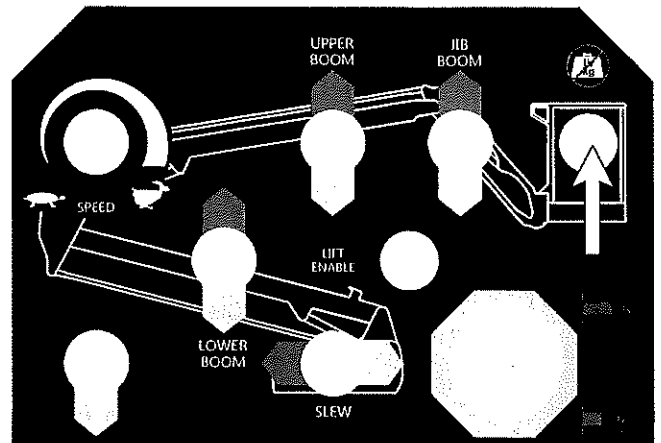

Figure 2.9 - Overload Indicator, Lower Control Box

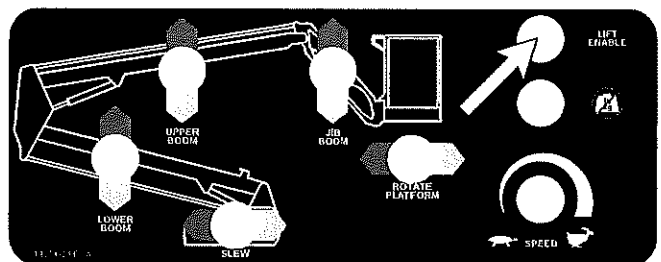

Figure 2.10 - Overload Indicator, Upper Control Box

**Bubble level**

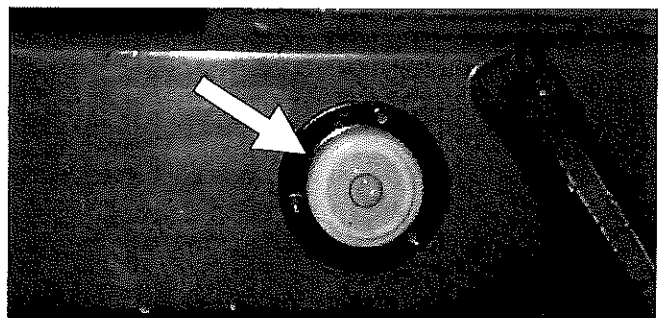

Figure 2.11 - Bubble Level

A bubble level is located on the trailer side rail, in front of the outrigger controls. Watch the bubble level while you set the outriggers. Lower the outriggers, one (1) at a time, just enough to center the bubble in the circle on top of the gauge. When the bubble is centered the platform is level and can be safely raised.

## 2. Safety Devices

### RCD/ELCB AC outlet

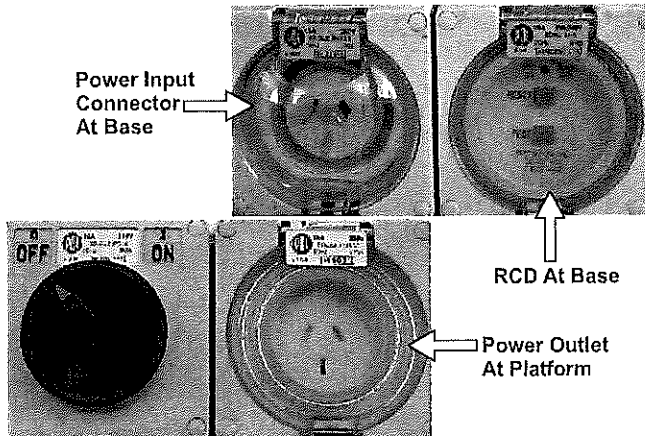

Figure 2.12 - RCD/ELCB AC Outlet

The RCD (Residual Current Device) is located at the base and will protect against short circuits to earth. When there is a short circuit the RCD will shut down the 230v AC power to the platform outlet.

To reset the outlet disconnect the power tool lead from the platform box and reset the RCD at the base.

If the problem persists call a trained service technician.

### Stabiliser/boom interlock test

All machines in the Snorkel 'MHP' Series of Trailer Mounted Elevating Work Platforms are fitted with a very important safety feature, a 'Stabiliser/Boom Interlock' system that prevents the booms being elevated to an unsafe position unless all four (4) stabilisers have been correctly set and have made firm contact with the ground.

This same safety feature also prevents the Stabilisers being operated while either or both Booms are elevated.

## ▲ IMPORTANT

**The correct operation of the Stabiliser/Boom Interlock is critical to ensure that the MHP is operated safely and without risk.**

Detailed instructions on how to carry out a test to ensure that this function is working correctly are provided at the beginning of the Pre-Operational Inspection chapter in this manual.

### Flashing light

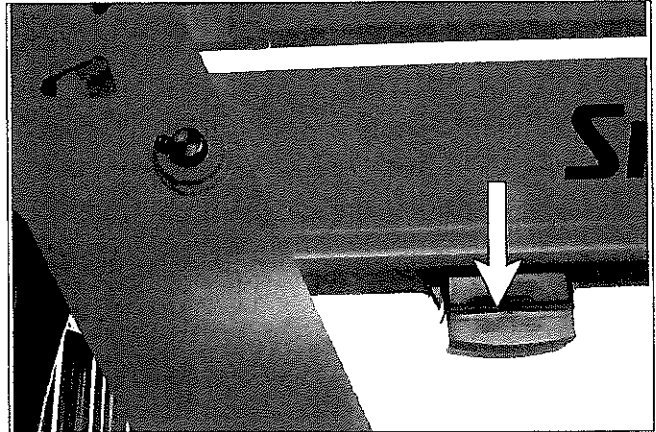

Figure 2.13 - Flashing Light

The flashing light alerts people that the MHP13/35 / MHP15/44 V3 is moving. The light flashes at about one (1) flash per second any time the MASTER KEY switch is on. There is no ON/OFF switch for the flashing light, it cannot be turned off while the MHP13/35 / MHP15/44 V3 is running.

### 10.9m height restriction kit (Option)

This kit may be fitted to MHP15/44 Mark II machines manufactured for the Australian market.

It is fitted to restrict the maximum height to the platform floor to 10.9m from the ground. This is to allow the unit to be operated by unlicensed operators in accordance with Australian legislation.

#### **Note:**

*See the Options chapter for details concerning this kit.*

## ■ Operating Procedures

This chapter explains how to properly start and operate an MHP13/35 / MHP15/44 V3. Read and understand all the previous chapters in this manual before you begin to operate an MHP13/35 Mark II. **If you have a Bi-energy machine you will also need to read the relevant section in the Options chapter in conjunction with this chapter.**

### ▲ CAUTION

If you use the MHP13/35 / MHP15/44 V3 for painting be sure the optional sandblast protection kit is installed to protect the hydraulic cylinder rods from paint. Do not leave the MHP13/35 / MHP15/44 V3 engine running if you are sandblasting. Sand drawn into the air intake can erode engine parts.

## ■ Control Stations

An MHP13/35 / MHP15/44 V3 can be operated from the ground control box or from the platform control box. There are basically two differences between ground control and platform control operations, both are safety related:

1. The ground control box can override the platform control box at any time. If a person operating the machine from the platform becomes incapacitated, a person on the ground can always take over machine control.
2. The outriggers can only be selected from the ground control box and only when the booms are in the stowed position.

### ▲ DANGER

The MHP13/35 / MHP15/44 V3 is not Electrically Insulated.

Death or Serious Injury to operating personnel, can occur if the machine should come into contact with energised electrical wires during operation.

**DO NOT** attempt to operate the MHP13/35 / MHP15/44 V3 ground controls if the platform, booms, or any other conducting part of an MHP13/35 / MHP15/44 V3 is in contact with energised electrical wires or if there is an immediate danger of such contact.

### NOTE

See the "Electrical Hazard" section, in this manual for a complete explanation of the hazards concerning electricity.

## ■ Emergency Stopping Lower Control Box

To stop an MHP13/35 / MHP15/44 V3, from the lower control box push the **Emergency Stop** switch in (see Figure 8.1).

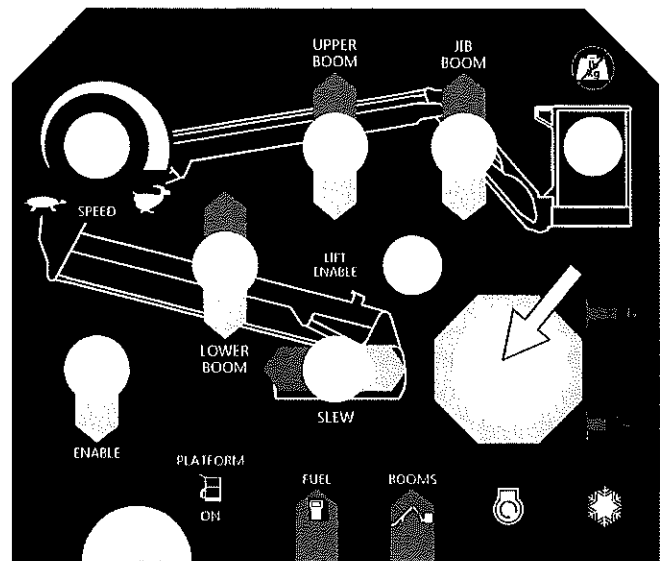

Figure 8.1 - Ground Control Box Emergency Stop Switch Location.

## ■ Emergency Stopping Upper Control Box

To stop an MHP13/35 / MHP15/44 V3 from the upper control box push the **Emergency Stop** switch in (see Figure 8.2).

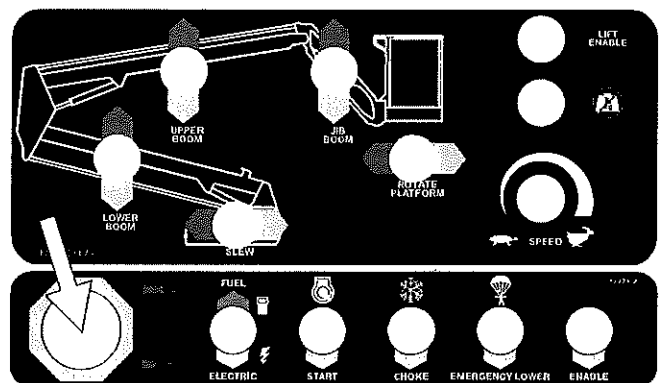

Figure 8.2 - Platform Control Box Emergency Stop Switch Location.

### NOTE

For a complete discussion of the **Emergency Stop** switches, see "Controls" chapter 6, in this manual.

## 8. Operation

### ■ Operation Considerations

To use this chapter, first decide whether you will be starting and operating the MHP13/35 / MHP15/44 V3 from the ground control box or the platform control box.

Begin at the section entitled "Starting From Ground Control Box", if you intend to start and run the MHP13/35 / MHP15/44 V3 from the ground station.

Begin at the section entitled "Starting From Platform Control Box", if you intend to start and run the MHP13/35 / MHP15/44 V3 from the platform.

### ■ Stabiliser Operation

#### **NOTE:**

*The stabilisers will only function when the booms are stowed. Once the booms are raised the stabilisers will not operate.*

*Before operating the stabilisers check to see that the ground conditions under the four (4) stabiliser pads is firm, stable and unobstructed.*

### **▲ DANGER**

If the platform is up and the ground compresses unevenly under different stabiliser pads the MHP might tip over causing serious injury or death. Check the level bubble frequently during operation. If any movement of the bubble occurs, immediately lower the platform and readjust the stabilisers to re-center the bubble in the ring.

Always check that all four (4) feet are clear of man-hole covers, drains etc., which may collapse. If the ground is at all soft, steel plates at least 300mm x 300mm x 6mm should be placed under the feet to spread the weight.

Ensure the boom/stabiliser switch (item ⑤ on the ground control box) (see Figure 8.5) is set to stabiliser.

Activate the stabilisers (see Figure 8.3) with the valve levers ensuring that the front stabilisers are lowered first to prevent damage to the jockey wheel.

Activate the rear stabilisers and level the machine using the level bubble adjacent to the control levers.

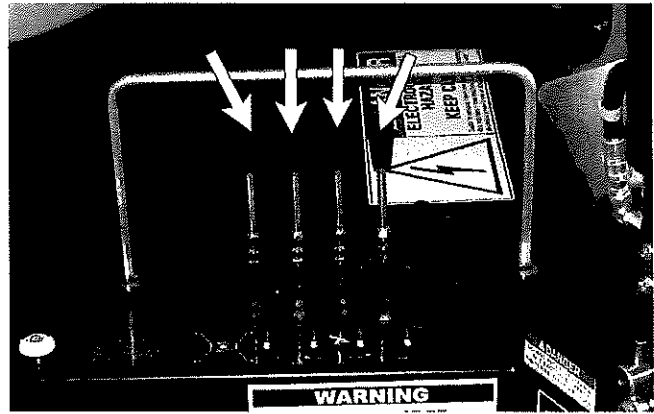

Figure 8.3 - Manual Stabiliser Valve Levers

### **▲ WARNING**

When levelling the machine in either the manual or automatic mode care is required to ensure that all of the foot plates are firmly on the ground, the machine is level and the lift enable light (item ③ Fig 8.5, and item ③ Fig 8.4) is ON before entering the platform.

### ■ Self Levelling Stabilisers (Option)

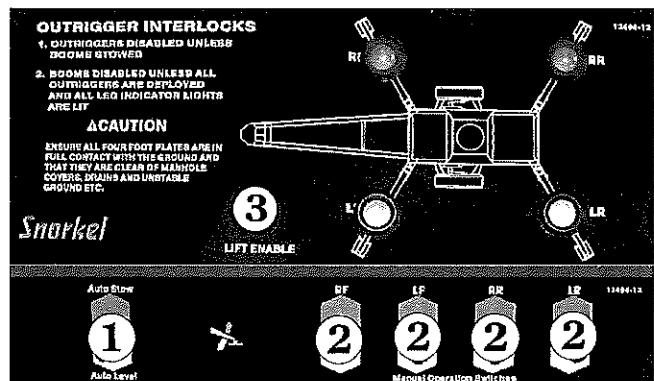

Figure 8.4 - Auto Level Controls

For units fitted with self levelling stabilisers the following applies.

1. Press and hold down the auto level switch ①.

The stabilisers will lower and the machine will "level" automatically.

#### **NOTE:**

Switch ① is also used to raise the stabilisers to the stowed position. To do so press and hold switch ① in the auto stow direction and all the stabilisers will raise automatically to the stowed position.

**NOTE:**

Although this option is designed to automatically set the stabilisers it is also possible to set the stabilisers manually.

### □ Setting the stabilisers manually

1. Operate each switch ② (see Figure 8.4) to raise or lower each stabiliser one (1) at a time. Use the level bubble (see Figure 2.7 in Safety Devices Chapter) to check the machine is level.

## ▲ WARNING

When levelling the machine in either the manual or automatic mode care is required to ensure that all of the foot plates are firmly on the ground, the machine is level and the lift enable light is ON before entering the platform.

### ■ Starting From Ground Control Box

Before you begin to operate the MHP13/35 / MHP15/44 V3 from the ground control box, a qualified operator must perform the "Daily Inspection and Maintenance" as described in chapter 7, of this manual.

To start the engine from the ground control box do the following:

1. Set the **Emergency Stop** switch ① to ON (see Figure 8.5).

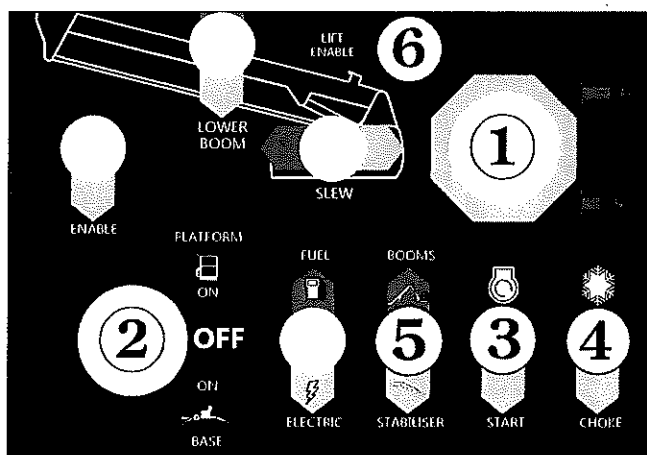

Figure 8.5 - Ground Control Box Starting

2. Insert the key and set the **Platform/Ground Selector** switch ② to GROUND (see Figure 8.5).
3. If the engine is at ambient temperature (cold), hold the **Choke / Cold Start** Switch ④ DOWN throughout the next step.

5. Press DOWN on the **Start Switch** and hold it there until the engine starts or for a maximum time of 6 seconds. When the engine starts release the start switch ③ and the choke switch ④, if you used it (see Figure 8.5).

## ▲ CAUTION

If the engine does not start in 6 seconds release the start switch and release the choke. Wait 60 seconds before trying to restart the engine again. Continual cranking of the starter motor will only result in its damage.

The engine should now be running, and the MHP is ready to begin work.

### ■ Starting From Platform Control Box

Before you begin to operate the MHP13/35 / MHP15/44 / MHP15/44 Mark II from the platform control box, a qualified operator must perform the "Daily Inspection and Maintenance" as described in chapter 7, of this manual.

To start the engine from the platform control box you must first set some switches on the ground control box, including setting the outriggers and leveling the machine.

(See page 8-2 for information on setting the stabilisers)

1. Insert the key ① into the **Platform / Ground Selector Switch** at the ground control box and select PLATFORM (see Figure 8.6).

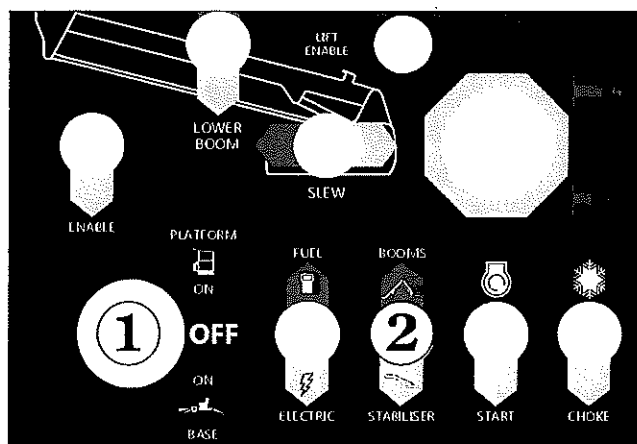

Figure 8.6

2. Set the **Booms / Stabiliser Selector** Switch ② (see Figure 8.6) at the ground control box to BOOMS.

## 8. Operation

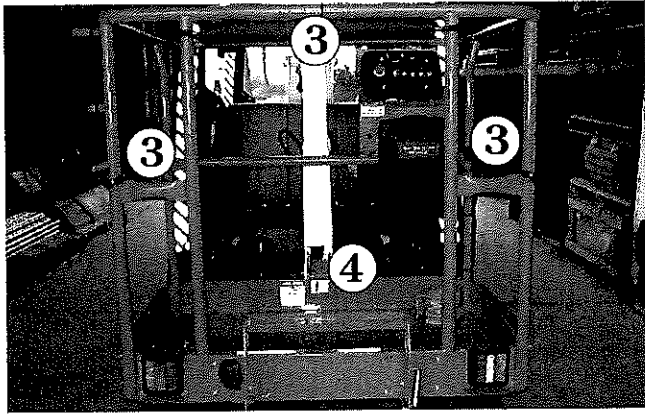

Figure 8.7

3. Enter the platform, close the gravity gate **3**, and attach the lanyard of your safety harness to one (1) of the anchor points **4** (see Figure 8.7).

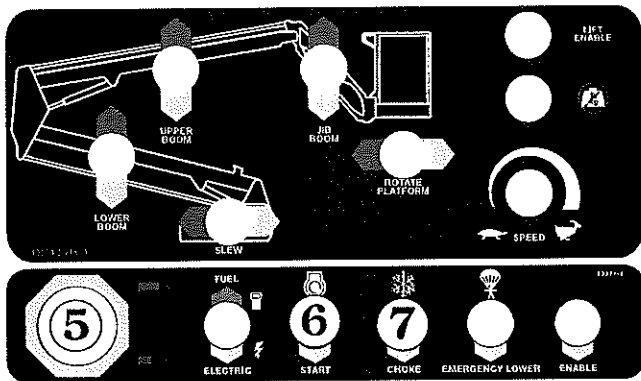

Figure 8.8

4. Set the **Emergency Stop** switch **5** to (ON) (see Figure 8.8).
5. If the engine is at ambient temperature (cold), hold the **Choke Switch** **7** (see Figure 8.8) DOWN throughout the next step.
7. Press down on the **Start Switch** **6** and hold it there until the engine starts or for a maximum time of 6 seconds. When the engine starts, release the start switch **6** and the choke switch **7**, if you used it (see Figure 8.8).

### ▲ CAUTION

If the engine does not start in 6 seconds, release the start switch and release the choke. Wait 60 seconds before trying to restart the engine again. Continual cranking of the starter motor will only result in its damage.

The engine should now be running, and the MHP13/35 / MHP15/44 V3 is ready to begin work.

### ■ Moving The Platform

The engine should already be running (as described earlier in this chapter), before you start this section.

### ▲ DANGER

DO NOT operate near energised electrical conductors. Maintain the (M.S.A.D.), Minimum Safe Approach Distance to energised power lines. See the "Electrical Hazard" section, in this manual for a complete explanation of the hazards concerning electricity. Maintain the clearances shown on the decal attached to the platform.

### ▲ WARNING

Be certain that the space into which you are about to move the platform, boom, turntable, and/or chassis is free of obstructions. ALWAYS look in the direction of movement.

When you operate from the platform control box, be sure that the lanyard of your safety harness is attached to an anchor point on the platform mount. Also, be sure that platform gate is closed behind you.

#### □ From Ground Control Box

Each of the ways the platform can move is shown in the following illustration:

These platform moving switches, (**1** through **4**), will produce the following movement .

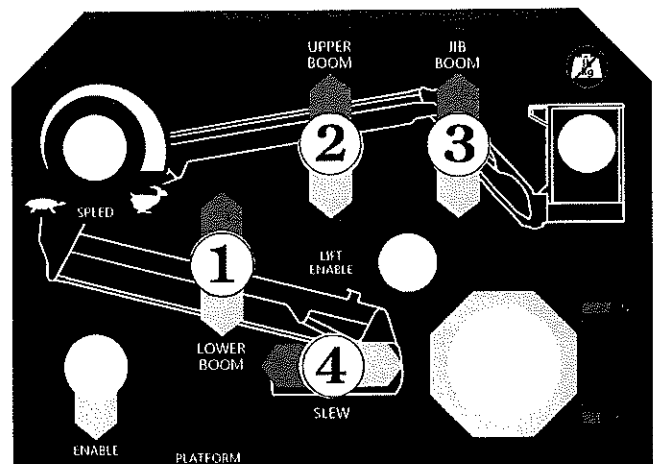

Figure 8.9 - Movement Control, Ground Control Box

1. **Lower Boom Switch:** Moving this switch UP will raise the lower boom, whilst pressing it DOWN will cause the lower boom to descend.

2. **Upper Boom Switch:** Moving this switch UP will raise the upper boom, whilst pressing it DOWN will cause the upper boom to descend.
3. **Jib Boom Switch:** Moving this switch UP will raise the jib boom, whilst pressing it DOWN will cause the jib boom to descend.
4. **Slew Switch:** Pressing the switch to the RIGHT causes the column/boom/platform assembly to rotate to the right, whilst pressing the switch to the left causes the column/boom/platform assembly to rotate to the left.

### ▲ IMPORTANT

You must operate the enable control in conjunction with the platform moving switches.

This is a safety feature to prevent the platform from moving if a platform moving switch, or controller, is accidentally pushed.

(For details see "Safety Devices" chapter)

- From Platform Control Box

### ▲ WARNING

When you operate from the platform control box, be sure that the lanyard of your safety harness is attached to the anchor point on the platform.

Each of the ways the platform can move is shown in the following illustration:

These platform moving switches, (1 through 5), will produce the following movement.

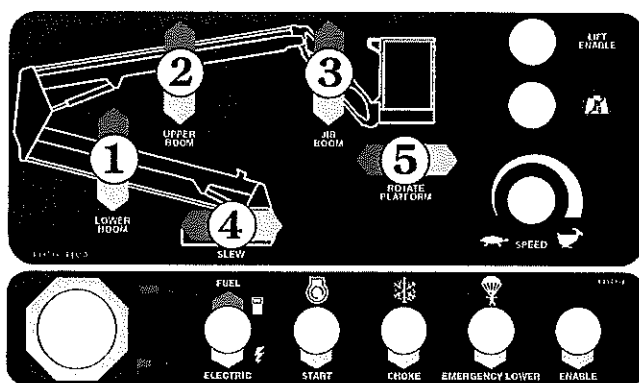

Figure 8.10 - Movement Control, Platform Control Box

1. **Lower Boom Switch:** Moving this switch UP will raise the lower boom, whilst pressing it DOWN will cause the lower boom to descend.

2. **Upper Boom Switch:** Moving this switch UP will raise the upper boom, whilst pressing it DOWN will cause the upper boom to descend.
3. **Jib Boom Switch:** Moving this switch UP will raise the jib boom, whilst pressing it DOWN will cause the jib boom to descend.
4. **Slew Switch:** Pressing the switch to the RIGHT causes the column/boom/platform assembly to rotate to the right, whilst pressing the switch to the left causes the column/boom/platform assembly to rotate to the left.
5. **Platform Rotate Switch (Option):** Pressing the switch (when fitted), to the left rotates the platform to the left. Pressing the switch to the right rotates the platform to the right.

### ▲ IMPORTANT

You must operate the enable control in conjunction with the platform moving switches.

This is a safety feature to prevent the platform from moving if a platform moving switch, or controller, is accidentally pushed.

The foot switch performs the same function as the standard enable switch described above. Stepping on the foot switch is an action that must be performed, at the same time as another action, to make the platform move.

#### Note:

If you have the optional 'foot switch' fitted this is an "and" option and the Enable switches on the Lower and Upper Control Boxes will still function.

(For details see "Safety Devices" chapter)

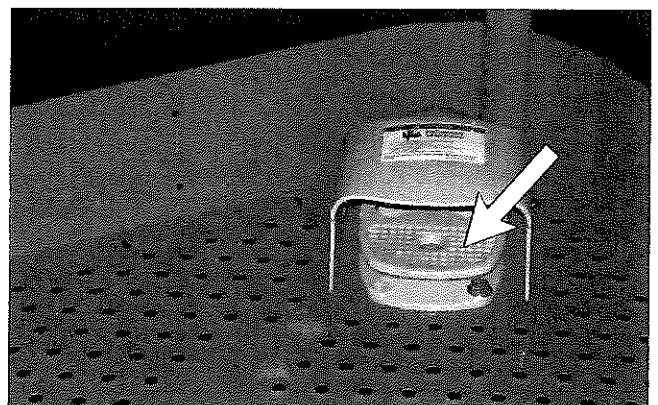

Figure 8.11 - Platform Foot Switch (Option)

## 8. Operation

---

### ■ Securing for Day

At the end of each work day the MHP13/35 / MHP15/44 V3 should be returned to the STOWED POSITION and locked as described under "Stowing" in the "Stowing and Transporting" chapter 10.

## ■ Emergency Operation Procedures

The following procedures are emergency procedures only. **DO NOT** use them for normal operation. Their purpose is to get the platform and operator safely to ground when the MHP13/35 / MHP15/44 V3 will not start or some other problem keeps the platform from lowering in the normal way.

### □ Operation From Platform Control Box

Switch settings listed in the two (2) steps below must exist at the ground before emergency operation procedures will work at the platform control box:

#### ➡ Ground control station settings

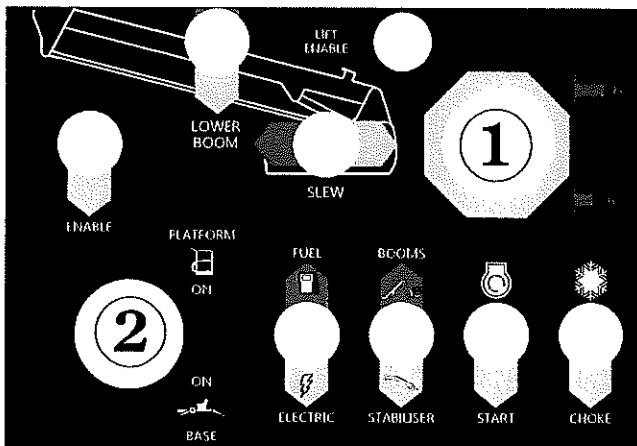

Figure 9.1 - Ground Control Box

1. The **Emergency Stop** switch **1** must be (ON) (see Figure 9.1).
2. The **Platform/Ground Selector** switch **2** (see Figure 9.1) must be set to PLATFORM.

#### ➡ Platform control station

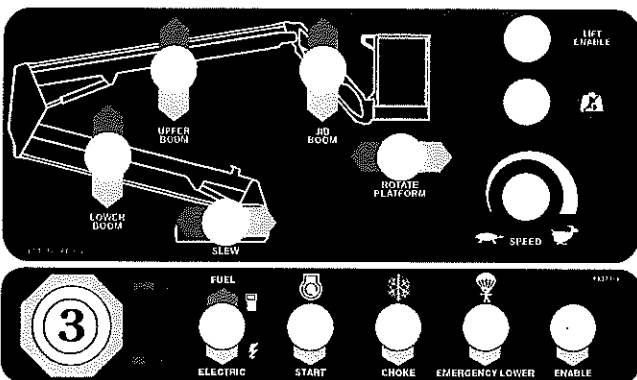

Figure 9.2 - Platform Control Box

3. Set the **Emergency Stop** switch **3** to ON (see Figure 9.2).

## ▲ IMPORTANT

The MHP13/35 / MHP15/44 have an **ENABLE** switch fitted to the Upper & Lower control boxes. (see Chapter 6 for a full explanation of the operation of this switch).

Some machines will also be fitted with a **FOOT OPERATED ENABLE** switch.

On those machines fitted with the foot switch option, both the switch on the control box and the foot switch perform the same function.

However it is assumed that for units fitted with a foot switch this will be the preferred method of operation.

If the **FOOT OPERATED ENABLE SWITCH** option is installed on your machine go to Step 4 - otherwise go to Step 5.

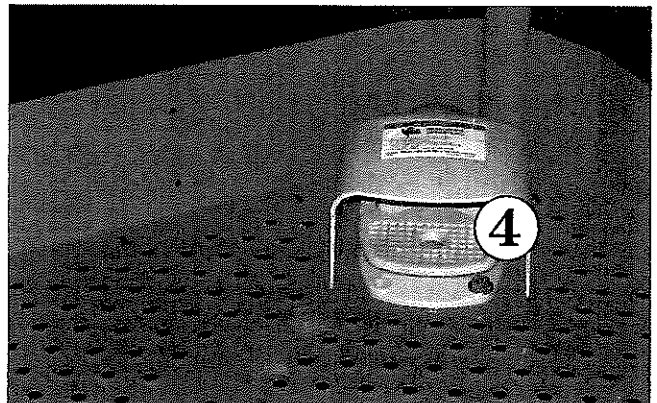

Figure 9.3 - Enable Switch (Foot)

4. Step on the platform foot switch **4** (see Figure 9.3).  
**Go to Step 6.**
5. Operate the Enable switch **5** by pressing the switch down and hold it down (see Figure 9.4).

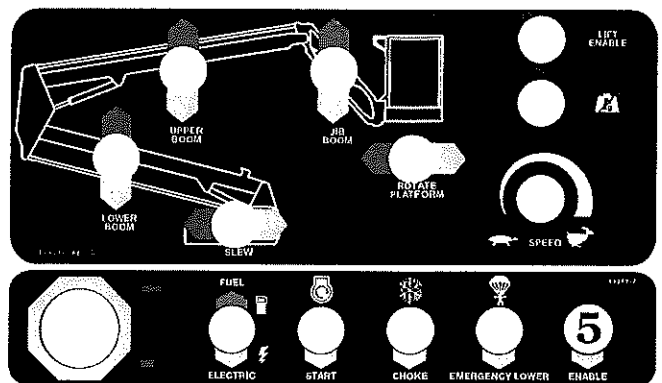
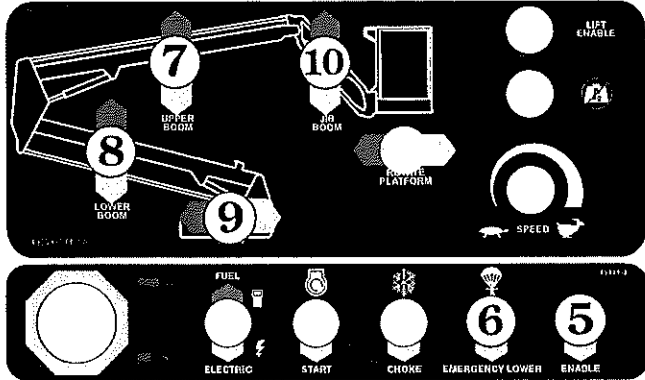

Figure 9.4 - Enable Switch; Platform Control Box

## 9. Emergency Operation



**Figure 9.5 - Platform Control Box**

6. Whilst still operating the enable switch, press and hold the **Emergency Lower** switch **6** down (see Figure 9.5) and the booms will begin lowering.
7. To **SLEW** during the emergency lower the following switches (see Figure 9.5) must be operated together.

Enable **5** or **4** (foot switch - Figure 9.3)  
**Emergency Lower 6**  
**Upper or Lower Boom Up 7 or 8**  
**Slew 9**

8. To Lower the jib boom during emergency lower the following switches (see Figure 9.5) must be operated together.

Enable **5** or **4** (foot switch - Figure 9.3)  
**Emergency Lower 6**  
**Upper or Lower Boom Up 7 or 8**  
**Jib 10**

Both booms will descend at the same time when lowering.

### **NOTE:**

When emergency lowering, it is only possible to Slew or lower the Jib Boom whilst the Upper and Lower booms are lowering.

### Operation From Ground Control Position

#### **CAUTION**

When performing this function, extreme care must be taken to ensure that the person carrying out the task does not become trapped by the structure as the booms descend.

#### **DANGER**

**DO NOT**, under any circumstances, climb down the elevating assembly to operate these valves.

There are two manual bleed down valves to operate from the ground position. One controls the descent of the lower boom and the other controls the descent of the upper boom.

The lower boom must be lowered first.

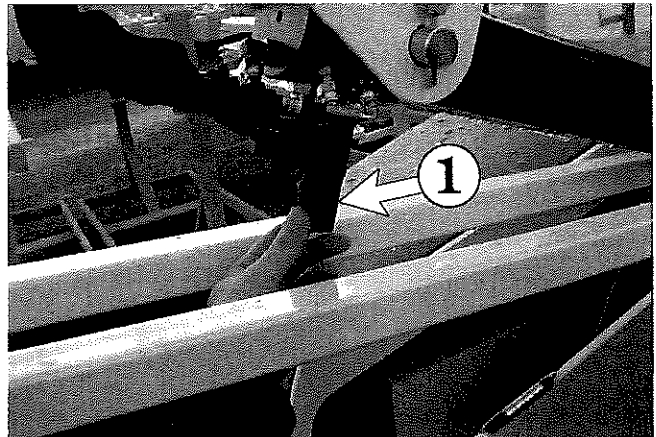

**Figure 9.5 - Manual Lower Valve, Lower Boom**

1. Open manual valve to lower the platform by turning the knob clockwise and holding it in that position as the boom lowers.

#### **CAUTION**

You will need to access the valve by reaching through the levelling rods (as shown in Figure 9.5) to prevent any danger of crushing to your hand.

2. When the boom has fully descended you can open the valve for the upper boom (see Figure 9.5.2).

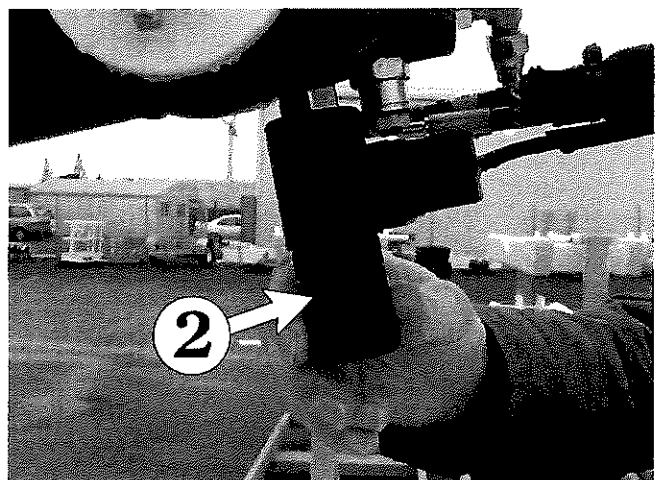

**Figure 9.5.2 - Manual Lower Valve, Upper Boom**

3. Open the manual valve for the upper boom, located at the base of the upper lift cylinder.

Operation of this valve is the same as for the previously described lower boom. The upper boom will begin to descend.

### **Note**

*It is not possible to slew during emergency lowering from the ground.*

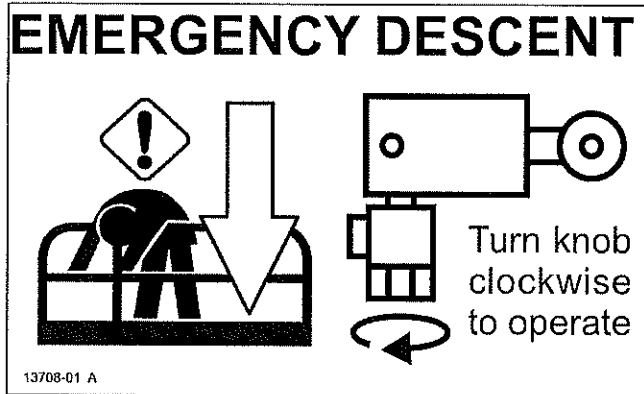

**Figure 9.6 - Manual Lowering Procedure Decal**